



**BAOSTEEL**

创享改变生活

# **BAOSTEEL** **Film-Laminated Steel**

宝钢覆膜铁产品手册

[www.baosteel.com](http://www.baosteel.com)

宝山钢铁股份有限公司  
BAOSHAN IRON & STEEL CO., LTD.



用户导向 合规经营 风险防控 安全健康



# 目录 CONTENTS

## 简介 / Introduction

- 01 产品系列 List of Products
- 02 产品结构 Product / Film Structure

01

## 产品特性 / Features

- 01 覆膜铁产品的优点 Advantages of Laminated Steel
- 02 覆膜铁产品的性能 Product Performance
- 03 宝钢覆膜铁的技术特点 Technology Characteristics

03

## 产品用途 / Applications

04

## 制造工艺 / Manufacturing Process

05

## 供货规格 / Available Specification and Size

05

- 01 尺寸规格 Available Size
- 02 调质度 Temper Grade
- 03 薄膜 Film Thickness and Color
- 04 涂蜡 Lubricating

## 使用须知 / Instruction and Precaution

06

## 包装和标识 / Packaging and Marking

07

## 订货产品标准 / Product Standard or Protocol

08

## 订货所需信息 / Requested Information of order or Inquiry

08



## 简介

### Introduction

覆膜铁是由高分子树脂薄膜和钢板组成的一种环保包装材，主要通过熔融法将聚对苯二甲酸乙二醇酯 (PET) 等薄膜覆合于镀铬板 (TFS)、镀锡板 (ETP)、冷轧板表面。覆膜铁产品具有优良的耐腐蚀、耐加工、易印刷等性能，可有效保障食品安全，可使得包装艳丽夺目。

宝钢股份是中国主要的镀锡产品制造商之一，具有先进的工艺装备、丰富的生产管理经验和良好的服务及一流的研发和制造队伍。宝钢拥有高端覆膜铁产线，不仅集成基板全流程技术、薄膜技术、覆膜工艺及装备技术、产品及使用技术，而且机组采用产品在线质量监测和在线生产精确控制技术，有效实现了覆膜铁产品稳定生产。宝钢覆膜铁产品已经广泛应用于食品、饮料、化工等领域的包装，获得用户好评。

Laminated Steel is green and low-carbon packaging material which is made of the multi-polymer film and the steel base, the steel trip such as TFS (Tin Free Steel) or ECCS (Electrolytic Chrome Coated Steel), electrolytic tinplate and cold rolling steel is combined with resin such as polyethyleneterephthalate (PET) by heating and melting. Laminated Steel can preserve food effectively with excellent merits in corrosion resistance, forming, printability, and so forth.

Baosteel is one of the largest manufacturers of tin-mill products in China with advanced technical equipments, first class inspection devices, skilled operators, excellent services and outstanding product development personnel. Baosteel has a self-developed laminated steel line of a higher level in domestic area, which is on basis of integrated technology including the base steel process, film, laminating process, equipment, product and application. The line is equipped with on line quality monitors and controllers in order to ensure the laminated steel is of stable and good performance. Baosteel's Laminated steel is widely applied to packaging of food, beverage and industrial goods and enjoys high reputation in the global market.



## 产品系列

### List of Products

镀铬覆膜铁 TFS-Based Film-Laminated Steel	一次冷轧镀铬覆膜铁 (SR TFS BF) Single Reduced TFS-Base Film-Laminated Steel
	二次冷轧镀铬覆膜铁 (DR TFS BF) Double Reduced TFS-Base Film-Laminated Steel
镀锡覆膜铁 Tinplate-Based Film-Laminated Steel	一次冷轧镀锡覆膜铁 (SR ETP BF) Single Reduced Electrolytic Tinplate-Base Film-Laminated Steel
	二次冷轧镀锡覆膜铁 (DR ETP BF) Double Reduced Electrolytic Tinplate-Base Film-Laminated Steel

注：宝钢覆膜铁产品包括4类，以BF开头，其中BFG是常规覆膜铁，BFE是高延伸覆膜铁，BFA是高附着性覆膜铁，BFX是特殊高要求的覆膜铁。

Note: Baosteel Film-Laminated Steel is classified into 4 sub groups as follows.

BFG stands for General Film-Laminated Steel

BFE stands for Film-Laminated Steel with High Elongation

BFA stands for Film-Laminated Steel with High Adhesion

BFX stands for Film-Laminated Steel with Special and High Requirement

## 产品结构

### Product / Film Structure

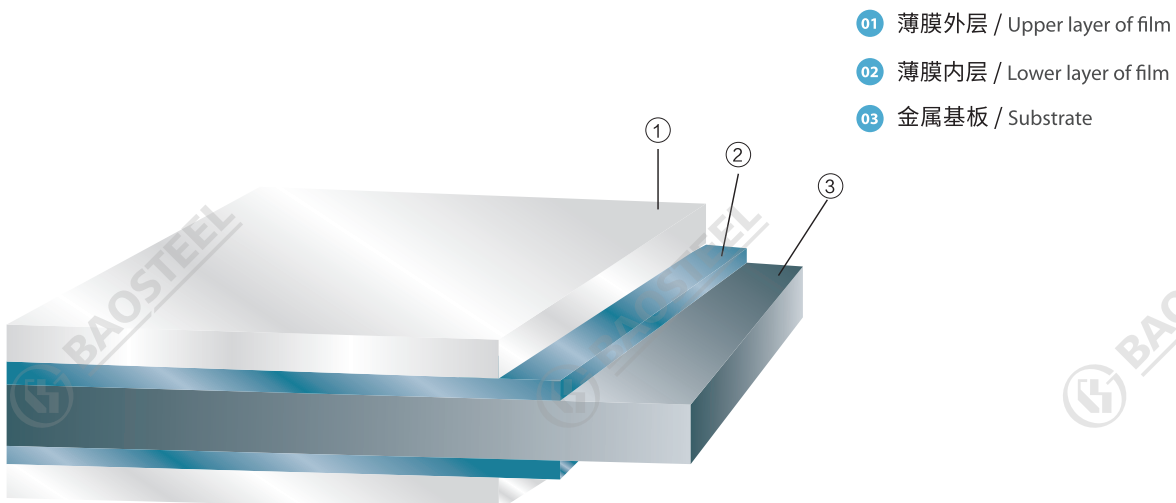

## 产品特性 Features

### 01 覆膜铁产品的优点 / Advantages of Laminated Steel

食品安全: 不含对人体有害的各种化学物质, 不使用粘着剂、溶剂, 确保人体健康、安全;

绿色低碳: 生产无溶剂挥发和废气排放, 加工不需要涂料及涂布烘烤, 对环境污染更少, 高效节能。

Food Safety: Keeping food hygienic and safe because of the film constituting no hazardous substance and the process without the adhesive and solvent.

Green and low-carbon: No solvent and exhaust emission without coating and curing process, accordingly there is less pollution and energy consumption and high-efficiency.

### 02 覆膜铁产品的性能 / Product Performance

高阻隔性能: 薄膜具有优异的阻隔及稳定性能, 能有效阻止腐蚀介质渗透, 保障食品在存储过程中的安全性;

高成形性能: 较高的抗拉强度和极好的延伸率使产品加工性能明显提升, 优良的耐磨性能有效防止加工中破损;

易印刷性能: 优异的着色性使膜的印刷极为便利, 印刷后色彩鲜艳, 外观亮丽。

Excellent Barrier: The immutable and stable film as an excellent barrier layer can separate the corrosive substance from steel base, thereby preserving food better during shelf life.

Excellent Formability: The film with higher strength and elongation and wear-resisting significantly improves on the complicate formability of laminated steel.

Excellent Printability: The film with excellent adhesion to ink makes printing convenient, and enhances color fastness and vividness and brilliant appearance.

### 03 宝钢覆膜铁的技术特点 / Technology Characteristics

全流程制造: 宝钢具备从冶炼、热轧、冷轧、电镀全流程的制造能力, 覆膜铁基板覆盖镀锌板、镀锡板、冷轧板。

自主集成技术: 宝钢覆膜铁产品集成了先进的基板技术、薄膜技术、覆膜工艺及装备技术、产品技术、使用技术等, 产品性能优异。

在线品质监控: 宝钢覆膜铁机组配置许多在线检测仪表如在线X衍射仪、在线膜孔仪等实时在线监测产品质量, 在线温度监测及反馈控制技术确保了产品质量的精确控制, 有效保证了宝钢覆膜铁产品的优异性能及质量稳定。

Complete manufacturing Process, steelmaking, hot rolling, cold rolling and TFS or ETP lines, the base steel for laminating covers TFS, ETP and CR plate.

Autonomous integration technology, film fabrication, laminating process, equipment technology, and application research, contributing to the excellent properties of products.

Online Quality Control, online pinhole detector monitoring film quality, and with online laminating temperature controller exerting precise adjustment, so that the excellent properties and quality steadiness of products is guaranteed.



覆膜铁机组 / Film-Laminated Line

## 产品用途

### Applications

主要用于中高端的食品、饮料包装, 包括顶底盖、易开盖、浅冲DRD罐、深冲DRD罐及其他异型罐/盖。也可用于包装油脂、颜料、喷雾剂等化学品的容器。

Baosteel's laminated steel can be used as packaging material not only for food and beverage but also for chemicals such as oil, paint, spray agent. It can be shaped into top end, EOE(Easy-Open-End), ordinary drawing can, deep drawing can, and other shaped can/end.

#### 顶底盖



#### Top or Bottom End



#### 易开盖



#### Easy Open End



#### 浅冲DRD罐



#### Ordinary Drawing Can



#### 深冲DRD罐



#### Deep Drawing Can



## 制造工艺 Manufacturing Process

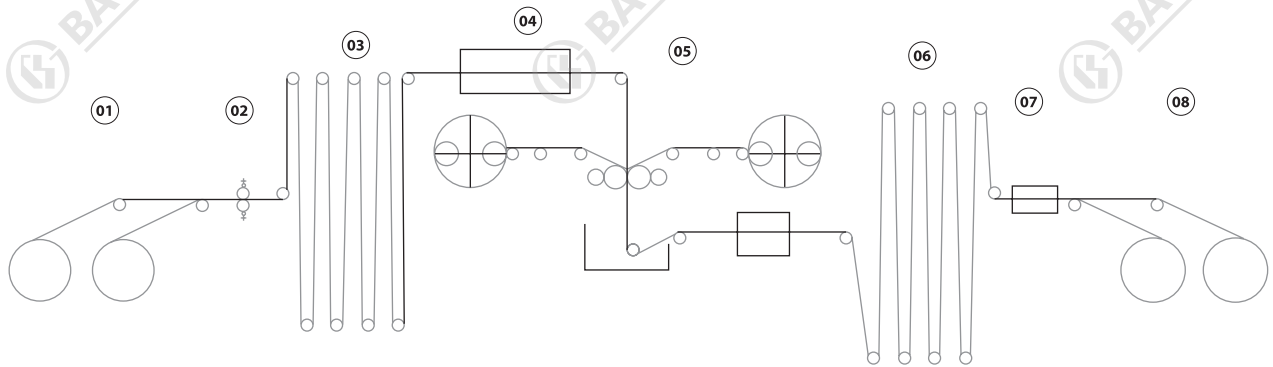

01 开卷机 / Uncoiler  
02 焊机 / Welder

03 入口活套 / Entry Looper  
04 加热单元 / Heating Unit

05 覆膜段 / Laminating Section  
06 出口活套 / Exit Looper

07 涂蜡 / Lubricating  
08 卷取机 / Coiler

## 供货规格 Available Specification and Size

### 01 尺寸规格 / Available Size

#### • 镀铬覆膜铁 TFS-Based Film-Laminated Steel

基板类型 Steel Base	公称厚度 Nominal Gauge	公称宽度 Nominal Width	公称长度 (钢板) Nominal Length(for Sheets)
一次冷轧SR	0.17~0.38mm	700~1050mm	500~1168mm
二次冷轧DR	0.14~0.36mm		

#### • 镀锡覆膜铁 Tinplate-Base Film-Laminated Steel

基板类型 Steel Base	公称厚度 Nominal Gauge	公称宽度 Nominal Width	公称长度 (钢板) Nominal Length(for Sheets)
一次冷轧SR	0.17~0.40mm	700~1050mm	500~1168mm
二次冷轧DR	0.14~0.36mm		



## 02 调质度 / Temper Grade

基板类型 Steel Base	连续退火 Continuous Annealing
一次冷轧SR	T-1, T-1.5, T-2, T-2.5, T-3, T-3.5, T-4, T-5
二次冷轧DR	DR-7, DR-7M, DR-8, DR-8M, DR-9, DR-9M, DR-10

## 03 薄膜 / Film Thickness and Color

薄膜颜色 Film Color	单面膜厚 Nominal Thickness of Single Side
透明 Clear	12~30μm
白色 White	
金色 Golden	

## 04 涂蜡 / Lubricating

若无特殊要求, 表面涂食品级蜡

There is food grade wax on surface of product unless otherwise agreed.

## 使用须知

## Instruction and Precaution

- 01 由于覆膜铁的膜层较软, 应采取适当保护措施, 以避免运输过程中的擦划伤。
- 02 由于覆膜铁性能具有时效性, 请在收货后尽快使用。
- 03 由于潮湿环境不利于覆膜铁的保存, 请在开包后尽快使用。

- 01 Due to softness of film, please take action to prevent it from scratch during delivery.
- 02 Due to the performance variation, please put it into production as soon as receiving the goods.
- 03 Due to the moisture damaging to the laminated steel, please use up the unpacked material as soon as possible.

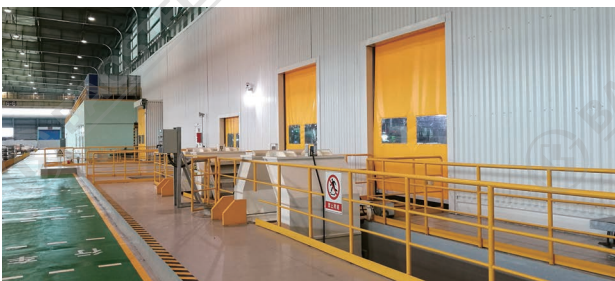

## 包装和标识 Packaging and Marking

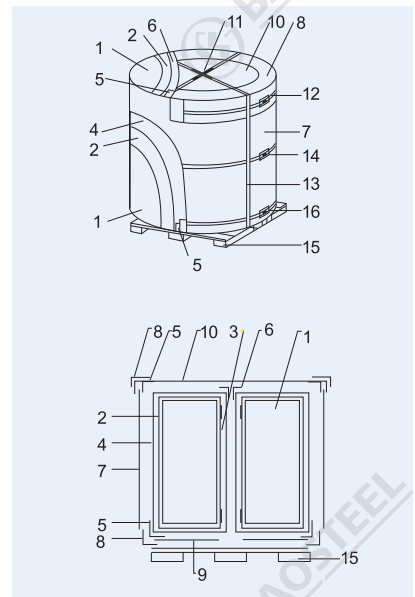
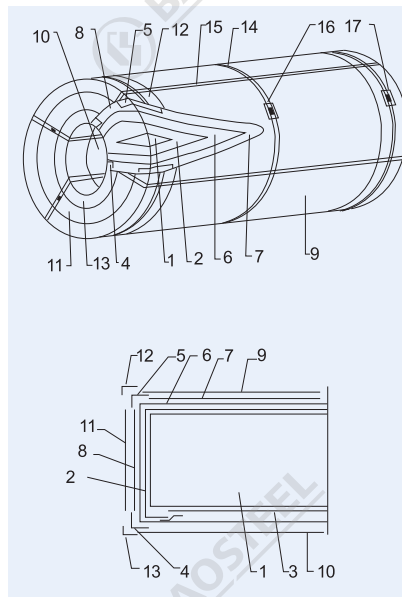
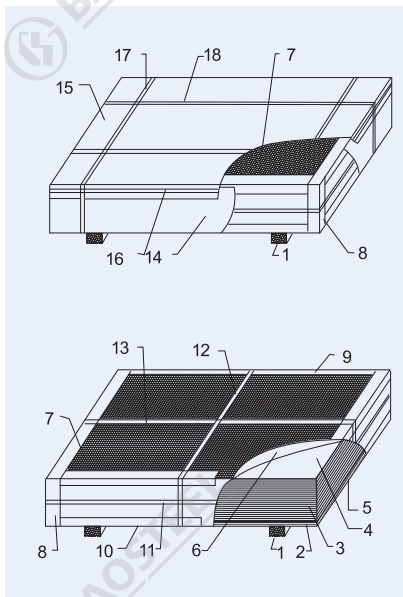

- 01 木台 / wood bracket
- 02 下盖板 / bottom cover
- 03 钢板 / steel sheet
- 04 上盖板 / top cover
- 05 底部瓦楞纸 / bottom corrugated paper
- 06 防锈纸 / rust-proof paper
- 07 上部瓦楞纸 / top corrugated paper
- 08 边部护角 / side corner guard
- 09 上部护角 / top corner guard
- 10 下部护角 / bottom corner guard
- 11 周向捆带(内) / circumferential banding strip(inner)
- 12 横向捆带(内) / horizontal banding strip (inner)
- 13 纵向捆带(内) / vertical banding strip (inner)
- 14 围板 / guard plate
- 15 盒盖 / steel package box
- 16 周向捆带(外) / circumferential banding strip (outer)
- 17 横向捆带(外) / horizontal banding strip (outer)
- 18 纵向捆带(外) / vertical banding strip (outer)

- 01 钢卷 / steel coil
- 02 外周防锈纸 / external peripheral rest-proof paper
- 03 内芯防锈纸 / inner core rest-proof paper
- 04 纸内护角 / paper inner corner guard
- 05 纸外护角 / paper external corner guard
- 06 塑料套 / plastic sleeve
- 07 外周瓦楞纸或纤维板 / external peripheral corrugated paper or fibreboard
- 08 圆护瓦楞纸 / round corrugated paper guard
- 09 外周护板 / external peripheral wrapping plate
- 10 内周护板 / inner peripheral guard plate
- 11 铁圆护板 / iron round cover
- 12 铁外护角 / iron external corner guard
- 13 铁内护角 / iron inner corner guard
- 14 周向捆带 / circumferential banding strip
- 15 径向捆带 / radial banding strip
- 16 锁扣垫片 / shim for lock
- 17 锁扣 / lock

- 01 钢卷 / steel coil
- 02 外周防锈纸 / external peripheral rest-proof paper
- 03 内芯防锈纸 / inner core rest-proof paper
- 04 纸内护角 / paper inner corner guard
- 05 纸外护角 / paper external corner guard
- 06 铁圆护板 / iron round cover
- 07 铁内护角 / iron inner corner guard
- 08 铁外护角 / iron external corner guard
- 09 外周护板 / external peripheral wrapping plate
- 10 内周护板 / inner peripheral guard plate
- 11 周向捆带 / circumferential banding strip
- 12 径向捆带 / radial banding strip
- 13 锁扣垫片 / shim for lock
- 14 锁扣 / lock

- 可提供钢卷和钢板产品，钢卷提供立式和卧式包装形式。
- 附有产品外标签和内标签。
- 您需要的包装形式和标签要求，请联系我们确认。

- Feasible in coils and sheets , coil packed eye to the sky or eye to the wall.
- A label that indicates the manufacturing history is affixed to the outside of the packaging. In addition, a service card is contained inside.
- With regard to types of packing and markings, please consult us.

## 订货产品标准 Product Standard or Protocol

订货按照 BQB 456-2023 覆膜铁钢板及钢带

Orders are in accordance with BQB 456-2023 (Film laminated steel sheet and strip)

## 订货所需信息 Requested Information of order or Inquiry

- 产品名称
- 本产品标准号
- 调质度
- 钢板尺寸及其精度 (包括厚度、宽度、长度、钢带内径等)
- 膜层厚度与颜色
- 涂蜡量
- 订货重量
- 包装方式
- 罐型/盖型
- 内容物
- 杀菌方式及条件
- 抗性要求
- 其他

- Product name
- Product standard or Technical Protocol
- Temper grade
- Specification and tolerance of steel base(Including thickness, width, inside diameter of coil, length of sheets, etc)
- Thickness and color of film
- Lubricant weight
- Weight
- Packaging
- End Use
- Type of content
- Conditions of sterilization
- Resistance requirement
- Others



冷板销售部

CRS Sales Department

地址:上海宝山漠河路151号  
邮编:201999  
电话:021-26641559

宝钢服务热线

Baosteel Service Hot-line

400-820-8590

宝钢慧创平台

iBaosteel

http://www.ibaosteel.com

国内贸易公司 Domestic Sales Channels

上海宝钢钢材贸易有限公司  
SHANGHAI BAOSTEEL  
STEEL PRODUCTS TRADING CO., LTD.  
TEL: 021-26640916

广州宝钢南方贸易有限公司  
GUANGZHOU BAOSTEEL  
SOUTHERN TRADING CO., LTD.  
TEL: 020-32219999

北京宝钢北方贸易有限公司  
BEIJING BAOSTEEL  
NORTHERN TRADING CO., LTD.  
TEL: 010-56512000

成都宝钢西部贸易有限公司  
CHENGDU BAOSTEEL  
WESTERN TRADING CO., LTD.  
TEL: 028-85335388

武汉宝钢华中贸易有限公司  
WUHAN BAOSTEEL  
CENTRAL CHINA TRADING CO., LTD.  
TEL: 027-84298800

沈阳宝钢东北贸易有限公司  
SHENYANG BAOSTEEL  
NORTH-EASTERN TRADING CO., LTD.  
TEL: 024-31391180

东北亚及澳洲大区 Northeast Asia and Oceania Region

宝和通商株式会社  
HOWA TRADING CO., LTD.  
TEL: 0081-3-32379121  
FAX: 0081-3-32379123

首尔事务所  
SEOUL OFFICE  
TEL: 0082-2-5080893  
FAX: 0082-2-5080891

BGM株式会社  
BGM CO., LTD  
TEL: 0082-70-44225903  
FAX: 0082-31-3514558

高雄事务所  
KAOHSIUNG OFFICE  
TEL: 00886-7-3356606  
FAX: 00886-7-3356609

宝钢澳大利亚贸易有限公司  
BAO AUSTRALIA PTY LTD.  
TEL: 0061-8-94810535  
FAX: 0061-8-94810536

东南亚及南亚大区 South East Asia and South Asia Region

宝钢新加坡贸易有限公司  
BAOSTEEL SINGAPORE PTE LTD.  
TEL: 0065-63336818  
FAX: 0065-63336819

宝新越南代表处  
VIETNAM OFFICE  
TEL: 0084-8-9100126  
FAX: 0084-8-9100124

宝新泰国代表处  
THAILAND OFFICE  
TEL: 0066-2-6368485  
FAX: 0066-2-2348989

宝新河内代表处  
HANOI OFFICE  
TEL: 0084-24-62694200  
FAX: 0084-24-62691392

宝钢印尼钢材加工有限公司(含印尼代表处)  
PT. BAOSTEEL INDONESIA STEEL SERVICE CENTER  
(INDONESIA OFFICE)  
TEL: 0062-21-3040 8575  
FAX: 0062-21-3040 8583

宝钢印度有限公司(含SANAND加工中心)  
BAOSTEEL INDIA COMPANY PRIVATE LTD.  
(SANAND STEEL SERVICE CENTER)  
TEL: 0091-22-30071700  
FAX: 0091-22-30071777

宝新马来西亚代表处  
MALAYSIA OFFICE  
TEL: 0060-32-2016986

欧非中东大区 Europe, Africa & Middle East Region

宝钢欧洲有限公司  
BAOSTEEL EUROPE GMBH  
TEL: 0049-89-32709090  
FAX: 0049-89-3270909130

宝钢西班牙有限公司  
BAOSTEEL ESPAÑA, S.L.  
TEL: 0034-93-4119325  
FAX: 0034-93-4119330

宝钢中东公司  
BAOSTEEL MIDDLE EAST FZE  
TEL: 00971-4-8840458  
FAX: 00971-4-8840485

宝欧南非代表处  
SOUTH AFRICA OFFICE  
TEL: 0027-11-7839985  
FAX: 0027-11-7842408

宝欧土耳其代表处  
TURKEY OFFICE  
TEL: 0090-212-3440067  
FAX: 0090-212-3440068

宝欧俄罗斯代表处  
RUSSIA OFFICE  
TEL: 7-499-2585602  
FAX: 7-499-2585602

宝钢意大利钢材集散中心有限公司  
BAOSTEEL ITALIA DISTRIBUTION CENTER SPA  
TEL: 0039-010-530881  
FAX: 0039-010-5308895

美洲大区 America Region

宝钢美洲有限公司  
BAOSTEEL AMERICA INC.  
TEL: 001-201-3073355  
FAX: 001-201-3073358

宝钢巴西有限公司  
BAOSTEEL DO BRAZIL LTDA.  
TEL: 0055-11-26678869

宝美加拿大代表处  
CANADA OFFICE  
TEL: 001-905-7315888/7315885  
FAX: 001-905-7315883

宝美圣地亚哥代表处  
SAN DIEGO OFFICE  
TEL: 001-949-7526789  
FAX: 001-949-7521234

宝美墨西哥代表处  
MEXICO OFFICE  
TEL: 0052-55-55319506  
FAX: 0052-55-55319506-201

宝美巴拿马代表处  
PANAMA OFFICE  
TEL: 507-382-5225

